

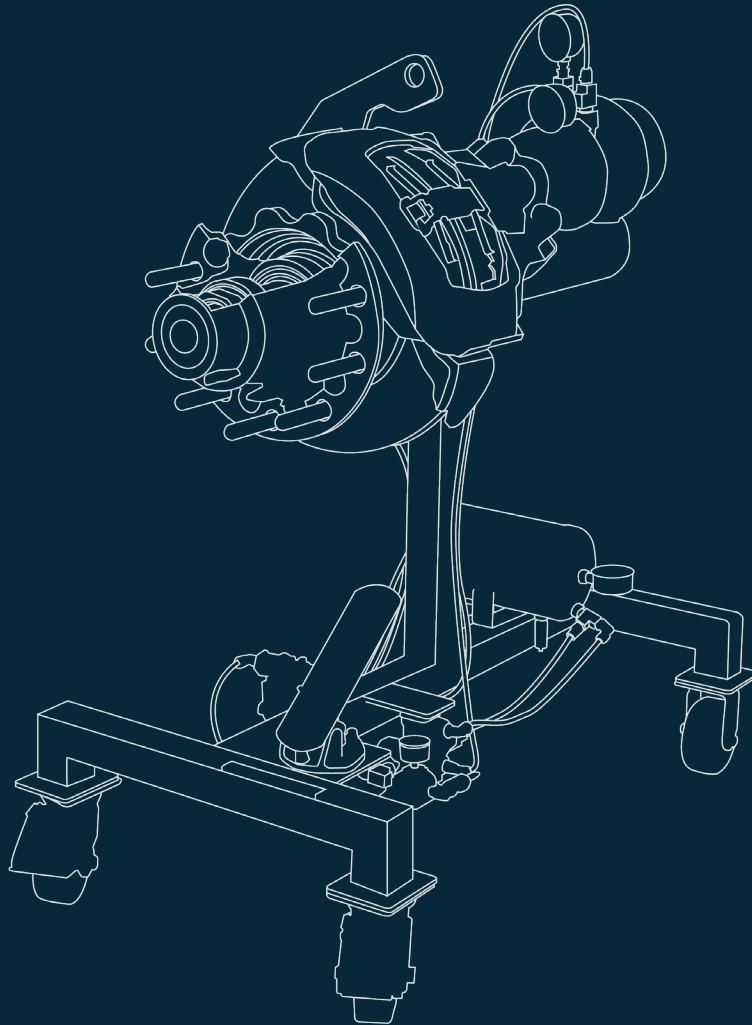

# Air disc wheel end training system with cutaways





The ConsuLab HV-126-DISC trainer includes a heavy duty truck disc assembly with air chamber. Using shop air; the service and parking brakes can be applied, the brake system can be dismantled, adjusted and the brakes can be measured. The trainer includes a sectional cutaway showing bearings, bearing races and caliper assembly.

**EDUCATIONAL  
ADVANTAGES**

- Allows full visualization of the air brake disc type assembly without the requirements of having a complete vehicle in the classroom
- Uses shop air to duplicate actual air brake disc type function
- Complete operational air brake disc type

**LIST OF COMPONENTS**

- Air disc assembly
- Shop air connection
- Connections for service and parking brake
- PP-1 push-pull type control valve
- E2 foot brake valve
- R-14 relay valve
- SR-5 anti-compound trailer spring brake valve
- Air reservoir with safety valve
- Three (3) pressure gauges
- Sectional cutaway that shows the bearings and bearing races
- One (1) mobile bench on casters (4) - two (2) are fixed and two (2) are swivel

**APPLICATION**

Bendix®

**TECHNICAL  
INFORMATIONS**

- **Dimensions:** 46 x 24 x 43 in (116.8 x 60.9 x 109.2 cm) / 48 x 48 x 46 in (121.9 x 121.9 x 116,8 cm) (w/packaging)
- **Weight:** 495 lb (225 kg) / 745 lb (338.8 kg) (w/packaging)

Scan this QR code for  
more about this product

